

DYMET ALLOYS SAW TIPS

Dymet Alloys offer a range of 'Ready to Braze' Tungsten Carbide Saw Tips.



- ◆ Grades:
 - Standard 6% cobalt.
 - Steel cutting and alternative grades available to special order.

- ◆ Quantity:
 - Saw Tips are available in multiples of 500-off.
 - Please note our minimum order value £50-00.

- ◆ Sizes:
 - Kerf sizes in the price list are usually ex-stock.
 - Other sizes available to special order, price on request.

Dymets Alloys specialise in manufacturing tungsten carbide products to individual customer specification. Other products / applications include Wear blocks, Bandsaw blade guides, shaped tips for cutter blades, cutters / burs and drills.



DYMET ALLOYS SAW TIP PRICE LIST

Grades:

Standard 6% cobalt.
Steel cutting and alternative grades available to special order.

Quantity:

Saw Tips are available in multiples of 500-off.
Please note our minimum order value £50-00.

A-SERIES SAW TIPS READY TO BRAZE (dimensions in mm)

DYMET CODE	Length	KERF Width	Thickness	500-2000	2500-5000	>5500
A-085	9.5	2.1	3.2		POA	
A-095	9.5	2.4	3.2		POA	
A-105	9.5	2.7	3.2		POA	
A-115	9.5	2.9	3.2		POA	
A-125	9.5	3.2	3.2		POA	
A-135	9.5	3.4	3.2		POA	
A-145	9.5	3.7	3.2		POA	
A-155	9.5	3.9	3.2		POA	
A-165	9.5	4.2	3.2	£0.215	£0.191	£0.184
A-175	9.5	4.5	3.2		POA	
A-185	9.5	4.7	3.2		POA	
A-195	9.5	5	3.2		POA	
A-205	9.5	5.2	3.2	£0.242	£0.218	£0.211
A-215	9.5	5.5	3.2		POA	
A-225	9.5	5.7	3.2	£0.255	£0.231	£0.224

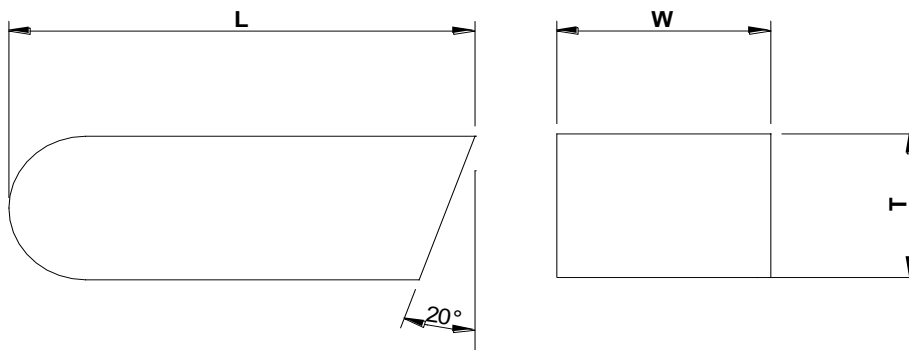



DYMET ALLOYS SAW TIP PRICE LIST

Grades:

Standard 6% cobalt.
Steel cutting and alternative grades available to special order.

Quantity:

Saw Tips are available in multiples of 500-off.
Please note our minimum order value £50-00.

B-SERIES SAW TIPS READY TO BRAZE (dimensions in mm)

DYMET CODE	Length	KERF Width	Thickness	500-2000	2500-5000	>5500
B-085	8	2.1	2.6	POA		
B-095	8	2.4	2.6	POA		
B-105	8	2.7	2.6	POA		
B-115	8	2.9	2.6	POA		
B-125	8	3.2	2.6	POA		
B-135	8	3.4	2.6	POA		
B-145	8	3.7	2.6	POA		
B-155	8	3.9	2.6	£0.175	£0.151	£0.144
B-165	8	4.2	2.6	POA		
B-175	8	4.5	2.6	£0.186	£0.163	£0.155
B-185	8	4.7	2.6	£0.190	£0.166	£0.159
B-195	8	5	2.6	£0.195	£0.172	£0.165
B-205	8	5.2	2.6	POA		
B-215	8	5.5	2.6	£0.205	£0.181	£0.174
B-225	8	5.7	2.6	POA		

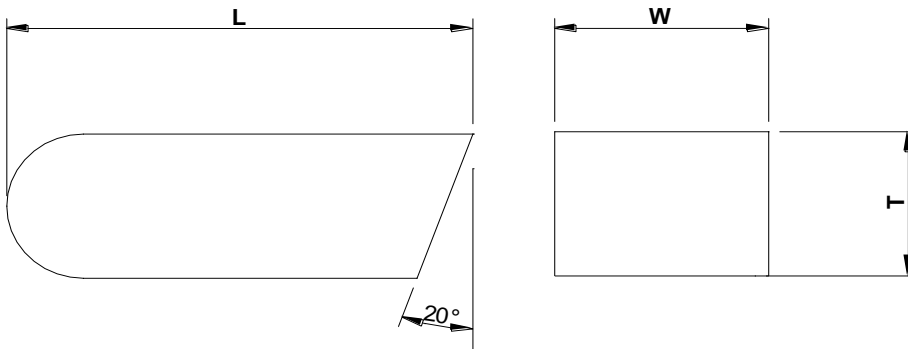



DYMET ALLOYS SAW TIP PRICE LIST

Grades:

Standard 6% cobalt.
Steel cutting and alternative grades available to special order.

Quantity:

Saw Tips are available in multiples of 500-off.
Please note our minimum order value £50-00.

F-SERIES SAW TIPS READY TO BRAZE (dimensions in mm)

DYMET CODE	Length	KERF Width	Thickness	500-2000	2500-5000	>5500
F-085	9.5	2.1	3.2	POA		
F-095	9.5	2.4	3.2	POA		
F-105	9.5	2.7	3.2	POA		
F-115	9.5	2.9	3.2	POA		
F-125	9.5	3.2	3.2	POA		
F-135	9.5	3.4	3.2	POA		
F-145	9.5	3.7	3.2	£0.146	£0.124	£0.119
F-155	9.5	3.9	3.2	£0.151	£0.129	£0.124
F-165	9.5	4.2	3.2	POA		
F-175	9.5	4.5	3.2	£0.166	£0.144	£0.139
F-185	9.5	4.7	3.2	£0.171	£0.149	£0.144
F-195	9.5	5	3.2	POA		
F-205	9.5	5.2	3.2	£0.183	£0.161	£0.156
F-215	9.5	5.5	3.2	£0.191	£0.169	£0.164
F-225	9.5	5.7	3.2	£0.196	£0.174	£0.169
F-235	9.5	6	3.2	£0.203	£0.181	£0.176
F-245	9.5	6.2	3.2	POA		
F-255	9.5	6.5	3.2	POA		
F-265	9.5	6.7	3.2	POA		
F-275	9.5	7	3.2	POA		
F-285	9.5	7.2	3.2	POA		
F-295	9.5	7.5	3.2	POA		
F-305	9.5	7.7	3.2	POA		
F-315	9.5	8	3.2	POA		

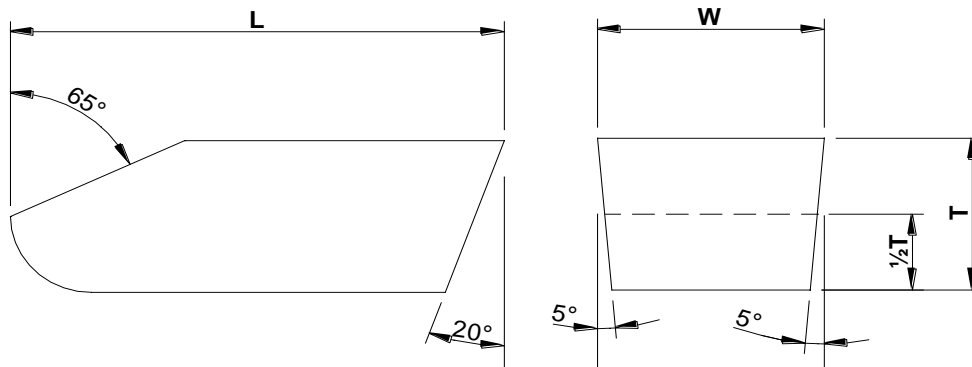



DYMET ALLOYS SAW TIP PRICE LIST

Grades:

Standard 6% cobalt.
Steel cutting and alternative grades available to special order.

Quantity:

Saw Tips are available in multiples of 500-off.
Please note our minimum order value £50-00.

H-SERIES SAW TIPS READY TO BRAZE (dimensions in mm)

DYMET CODE	Length	KERF Width	Thickness	500-2000	2500-5000	>5500
H-085	8	2.1	2.6	POA		
H-095	8	2.4	2.6	POA		
H-105	8	2.7	2.6	POA		
H-115	8	2.9	2.6	£0.103	£0.081	£0.076
H-125	8	3.2	2.6	£0.108	£0.086	£0.081
H-135	8	3.4	2.6	POA		
H-145	8	3.7	2.6	£0.117	£0.095	£0.090
H-155	8	3.9	2.6	£0.120	£0.098	£0.093
H-165	8	4.2	2.6	£0.125	£0.104	£0.098
H-175	8	4.5	2.6	£0.131	£0.109	£0.104
H-185	8	4.7	2.6	£0.134	£0.112	£0.107
H-195	8	5	2.6	£0.139	£0.117	£0.112
H-205	8	5.2	2.6	£0.143	£0.121	£0.116
H-215	8	5.5	2.6	£0.148	£0.126	£0.121
H-225	8	5.7	2.6	£0.151	£0.130	£0.124
H-235	8	6	2.6	POA		
H-245	8	6.2	2.6	POA		
H-255	8	6.5	2.6	POA		
H-265	8	6.7	2.6	POA		
H-275	8	7	2.6	POA		
H-285	8	7.2	2.6	POA		
H-295	8	7.5	2.6	POA		
H-305	8	7.7	2.6	POA		
H-315	8	8	2.6	POA		

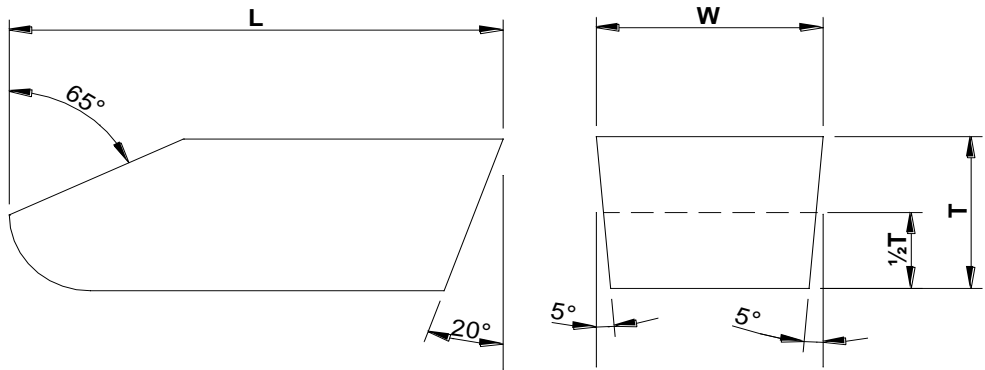



DYMET ALLOYS SAW TIP PRICE LIST

Grades:

Standard 6% cobalt.
Steel cutting and alternative grades available to special order.

Quantity:

Saw Tips are available in multiples of 500-off.
Please note our minimum order value £50-00.

G-SERIES SAW TIPS READY TO BRAZE (dimensions in mm)

DYMET CODE	Length	KERF Width	Thickness	500-2000	2500-5000	>5500
G-085	8.7	2.1	2.6	POA		
G-095	8.7	2.4	2.6	POA		
G-105	8.7	2.7	2.6	POA		
G-115	8.7	2.9	2.6	POA		
G-125	8.7	3.2	2.6	£0.165	£0.141	£0.134
G-135	8.7	3.4	2.6	POA		
G-145	8.7	3.7	2.6	£0.174	£0.151	£0.143
G-155	8.7	3.9	2.6	£0.178	£0.154	£0.147
G-165	8.7	4.2	2.6	£0.184	£0.160	£0.153
G-175	8.7	4.5	2.6	£0.190	£0.166	£0.159
G-185	8.7	4.7	2.6	£0.194	£0.170	£0.163
G-195	8.7	5	2.6	£0.199	£0.176	£0.168
G-205	8.7	5.2	2.6	£0.203	£0.179	£0.172
G-215	8.7	5.5	2.6	£0.209	£0.185	£0.178
G-225	8.7	5.7	2.6	£0.213	£0.189	£0.182

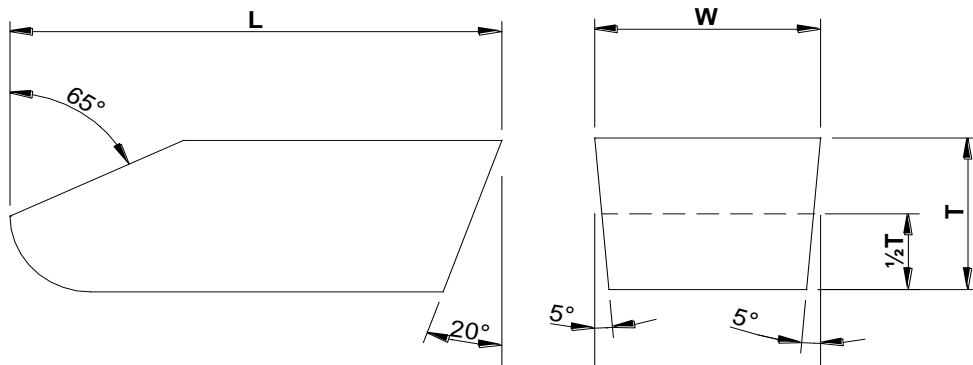



DYMET ALLOYS SAW TIP PRICE LIST

Grades:

Standard 6% cobalt.
Steel cutting and alternative grades available to special order.

Quantity:

Saw Tips are available in multiples of 500-off.
Please note our minimum order value £50-00.

J-SERIES SAW TIPS READY TO BRAZE (dimensions in mm)

DYMET CODE	Length	KERF Width	Thickness	500-2000	2500-5000	>5500
J-085	8	2.1	2	POA		
J-095	8	2.4	2	POA		
J-105	8	2.7	2	POA		
J-115	8	2.9	2	POA		
J-125	8	3.2	2	POA		
J-135	8	3.4	2	£0.100	£0.079	£0.073
J-145	8	3.7	2	£0.105	£0.083	£0.078
J-155	8	3.9	2	£0.107	£0.086	£0.080
J-165	8	4.2	2	£0.112	£0.090	£0.085
J-175	8	4.5	2	£0.116	£0.094	£0.089
J-185	8	4.7	2	£0.119	£0.097	£0.092
J-195	8	5	2	£0.123	£0.101	£0.096
J-205	8	5.2	2	£0.126	£0.104	£0.099
J-215	8	5.5	2	£0.130	£0.108	£0.103
J-225	8	5.7	2	POA		
J-235	8	6	2	POA		
J-245	8	6.2	2	POA		
J-255	8	6.5	2	POA		
J-265	8	6.7	2	POA		
J-275	8	7	2	POA		
J-285	8	7.2	2	POA		
J-295	8	7.5	2	POA		
J-305	8	7.7	2	POA		
J-315	8	8	2	POA		

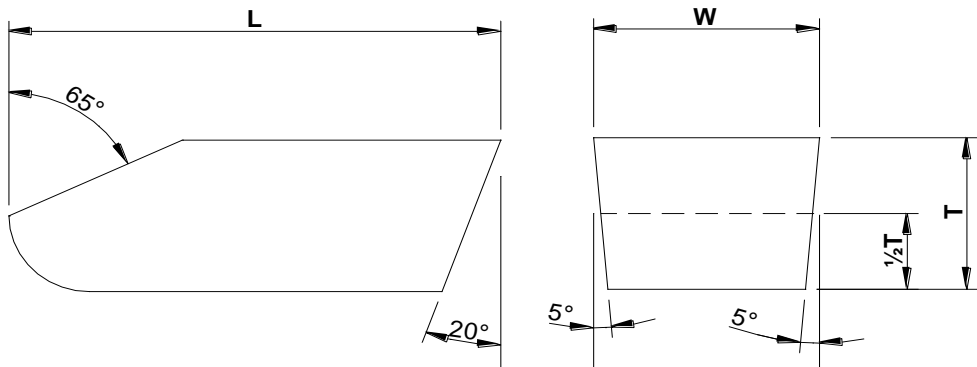



DYMET ALLOYS SAW TIP PRICE LIST

Grades:

Standard 6% cobalt.
Steel cutting and alternative grades available to special order.

Quantity:

Saw Tips are available in multiples of 500-off.
Please note our minimum order value £50-00.

P-SERIES SAW TIPS READY TO BRAZE (dimensions in mm)

DYMET CODE	Length	KERF Width	Thickness	500-2000	2500-5000	>5500
P-125	11	3.2	3.6	POA		
P-135	11	3.4	3.6	POA		
P-145	11	3.7	3.6	POA		
P-155	11	3.9	3.6	£0.176	£0.154	£0.148
P-165	11	4.2	3.6	£0.185	£0.163	£0.158
P-175	11	4.5	3.6	£0.194	£0.173	£0.167
P-185	11	4.7	3.6	£0.201	£0.179	£0.174
P-195	11	4.9	3.6	£0.207	£0.185	£0.180
P-205	11	5.2	3.6	£0.216	£0.195	£0.189
P-215	11	5.4	3.6	£0.223	£0.201	£0.196
P-225	11	5.7	3.6	£0.232	£0.210	£0.205
P-235	11	6	3.6	£0.242	£0.220	£0.215
P-245	11	6.2	3.6	£0.248	£0.226	£0.221
P-255	11	6.5	3.6	£0.257	£0.236	£0.230
P-265	11	6.7	3.6	POA		
P-275	11	7	3.6	£0.273	£0.251	£0.246
P-285	11	7.2	3.6	£0.279	£0.258	£0.252
P-295	11	7.5	3.6	£0.289	£0.267	£0.262
P-305	11	7.8	3.6	£0.298	£0.277	£0.271
P-315	11	8	3.6	£0.305	£0.283	£0.278
P-325	11	8.3	3.6	£0.314	£0.292	£0.287
P-335	11	8.5	3.6	£0.320	£0.299	£0.293

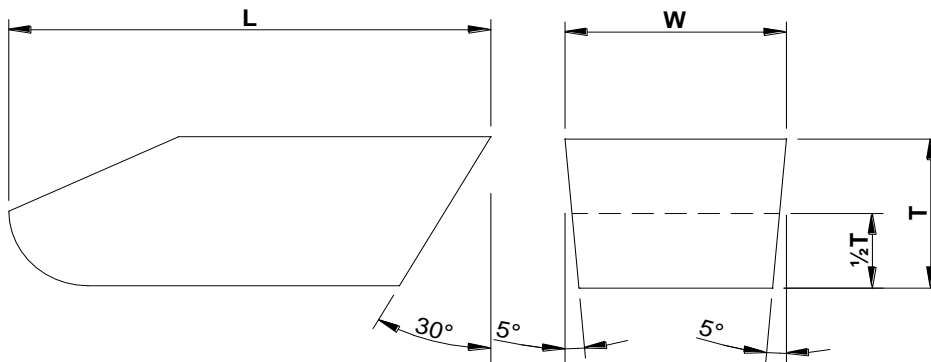



DYMET ALLOYS SAW TIP PRICE LIST

Grades:

Standard 6% cobalt.
Steel cutting and alternative grades available to special order.

Quantity:

Saw Tips are available in multiples of 500-off.
Please note our minimum order value £50-00.

N-SERIES SAW TIPS READY TO BRAZE (dimensions in mm)

DYMET CODE	Length	KERF Width	Thickness	500-2000	2500-5000	>5500
N-085	9.5	2.1	3.2		POA	
N-095	9.5	2.4	3.2		POA	
N-105	9.5	2.7	3.2		POA	
N-115	9.5	2.9	3.2		POA	
N-125	9.5	3.2	3.2		POA	
N-135	9.5	3.4	3.2		POA	
N-145	9.5	3.7	3.2		POA	
N-155	9.5	3.9	3.2		POA	
N-165	9.5	4.2	3.2		POA	
N-175	9.5	4.5	3.2		POA	
N-185	9.5	4.7	3.2		POA	
N-195	9.5	5	3.2		POA	
N-205	9.5	5.2	3.2		POA	
N-215	9.5	5.5	3.2		POA	
N-225	9.5	5.7	3.2		POA	
N-235	9.5	6	3.2		POA	
N-245	9.5	6.2	3.2		POA	
N-255	9.5	6.5	3.2		POA	
N-265	9.5	6.7	3.2		POA	
N-275	9.5	7	3.2		POA	
N-285	9.5	7.2	3.2		POA	
N-295	9.5	7.5	3.2		POA	
N-305	9.5	7.8	3.2		POA	
N-315	9.5	8	3.2		POA	

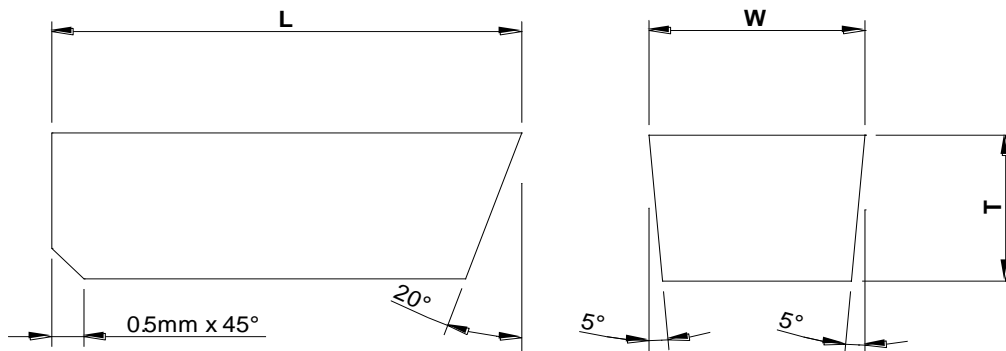



DYMET ALLOYS SAW TIP PRICE LIST

Grades:

Standard 6% cobalt.
Steel cutting and alternative grades available to special order.

Quantity:

Please note our minimum order value £50-00.

GROOVER TIPS READY TO BRAZE

DYMET CODE	Length	KERF Width	Thickness	0 - 100	101 - 500	>501
A-0200	12.8	2MM	4.3	£0.305	£0.217	£0.175
A-0300	12.8	3MM	4.3	£0.350	£0.263	£0.220
A-0317	12.8	1/8"	4.3	£0.356	£0.269	£0.226
A-0400	12.8	4MM	4.3	£0.396	£0.309	£0.266
A-0476	12.8	3/16"	4.3	£0.431	£0.344	£0.301
A-0500	12.8	5MM	4.3	£0.442	£0.355	£0.312
A-0600	12.8	6MM	4.3	£0.488	£0.401	£0.358
A-0635	12.8	1/4"	4.3	£0.504	£0.417	£0.374
A-0700	12.8	7MM	4.3	£0.534	£0.447	£0.404
A-0794	12.8	5/16"	4.3	£0.577	£0.490	£0.447
A-0953	12.8	3/8"	4.3	£0.648	£0.561	£0.518
A-1000	12.8	10MM	4.3	£0.671	£0.584	£0.541
A-1111	12.8	7/16"	4.3	£0.722	£0.635	£0.592
A-1200	12.8	12MM	4.3	£0.763	£0.676	£0.633
A-1270	12.8	1/2"	4.3	£0.795	£0.708	£0.665
A-1300	12.8	13MM	4.3	£0.809	£0.722	£0.679
A-1429	12.8	9/16"	4.3	£0.868	£0.781	£0.738
A-1588	12.8	5/8"	4.3	£0.942	£0.855	£0.812
A-1748	12.8	11/16"	4.3	£1.013	£0.926	£0.883
A-1800	12.8	18MM	4.3	£1.038	£0.951	£0.908
A-1903	12.8	3/4"	4.3	£1.086	£0.999	£0.956

Other sizes are available to special order. Price on application.

